

Gravel unloading trailer, 60m³, Fanps

for the transportation of shingel and gravel



Advantages

- Telematics
- Wagon for the transportation of shingel (> 6mm), stones and gravel, with rugged and proven unloading opening
- Unloading cylinders are arranged in the middle, accurate to dose, with central and lateral unloading
- Ideal for cargoes like gravels, shingels (> 6 mm) and stones



Payload

Load limit grid	A	B	C	D
S	42.0 t	50.0 t	58.0 t	69.0 t
120	00.0 t			

Tare weight 21'000 kg

Dimensions / Specifications

Loading capacity	60 m ³ (3 Trichter, axial)
Dimensions of the loading opening	11'224 mm x 1'966 mm
Number of unloading openings	3
Dimensions of unloading openings (in each case)	1'040 mm x 785 mm
Operation of the flaps	Manual, separate with a square socket

Dimensions / Specifications

Length over buffers	15'640 mm
Distance between outer wheelsets	12'400 mm
Track gauge	1'435 mm
Minimum curve radius	60 m
Ferry boat angle	1°30', R = 120 m
Length of subframe	14'400 mm

Technical Data

Operational area	TEN, G1, GE
Bogie	AFR 22
Axle load	22.5 t
Brake	KE-GP
Brake pad	LL IB116
Parking brake weight	7 t
Buffer	Kat. X
Safety equipment optional	Crash buffer Derailment detector Climbing protection

Gravel unloading trailer, 60m³, Fanps, side view

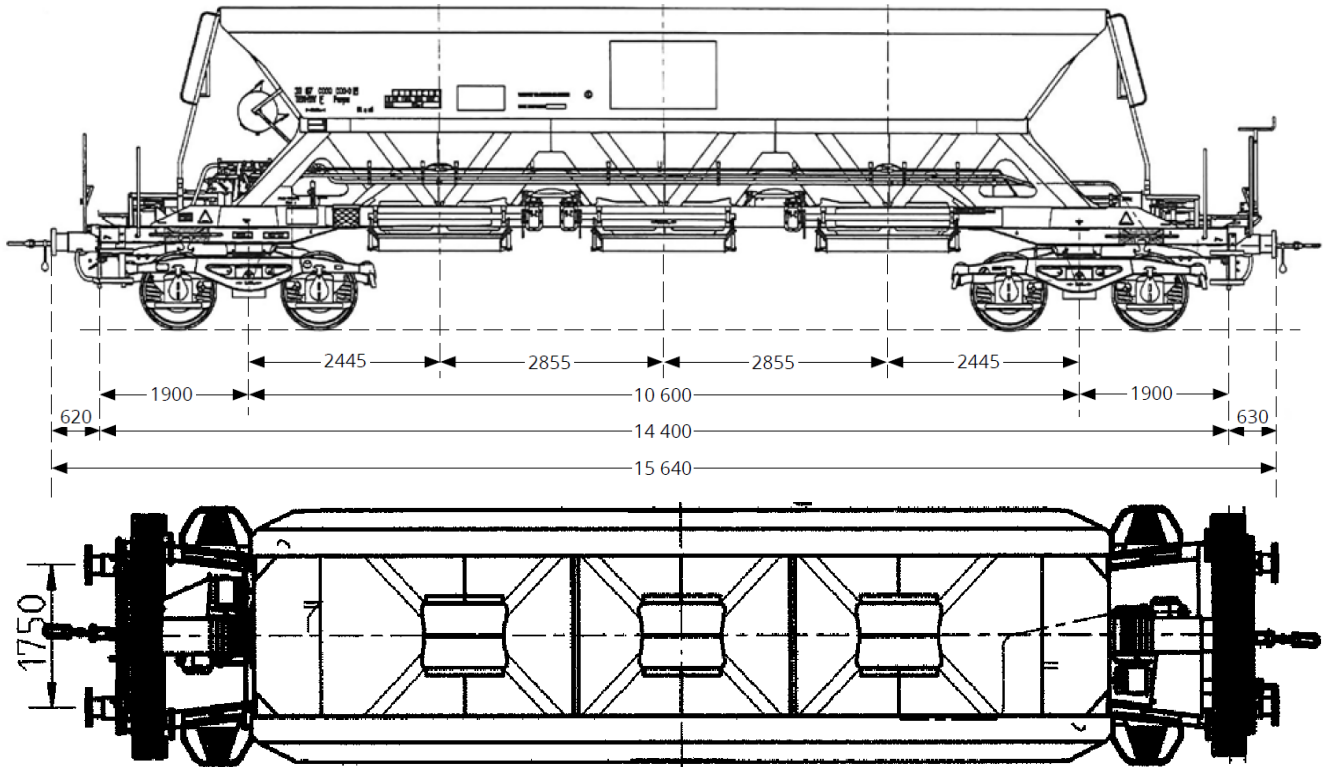

View handbrake end

View not-handbrake end

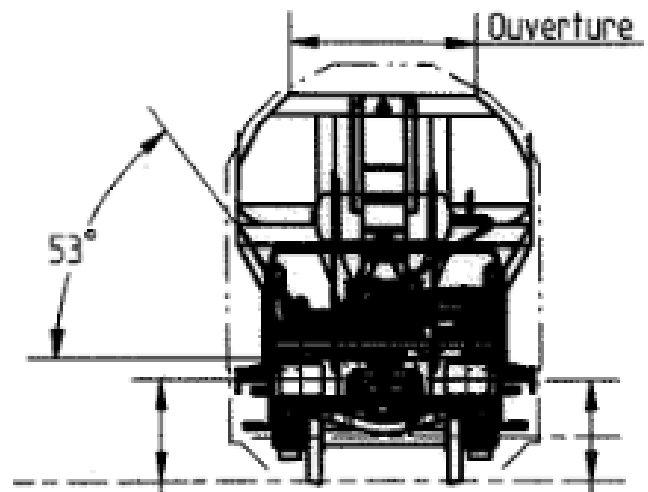
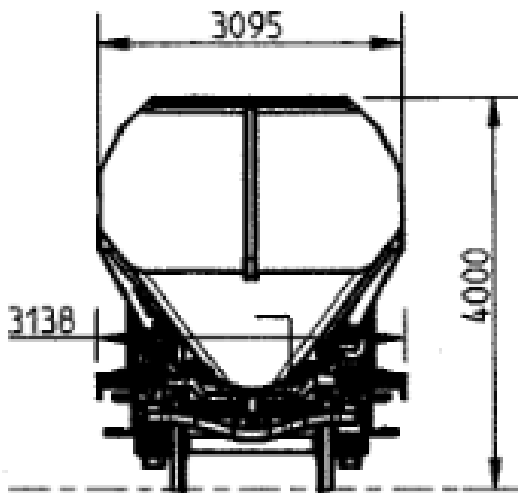

Unloading options

Centred unloading opening			Side unloading opening
Low-level bunker for centred unloading opening	onto continuous conveyors under the rail level	onto continuous conveyors on the rail level	onto stationary continuous conveyors on the rail level